

PACKAGING STANDARDS

for Fragile Merchandise

Last Amended: August 24, 2023

TABLE OF CONTENTS

1.0 PURPOSE	3
2.0 CARTON PERFORMANCE TESTING	4
2.1 General Information	4
2.2 Conditioning	4
2.3 Drop Test	4
2.4 Documentation.....	5
3.0 PACKAGING TERMS.....	6
3.1 Item.....	6
3.2 Shipping Carton	6
3.3 Inner Carton.....	6
3.4 Carton Dimensions	6
3.5 Flute.....	7
3.6 Single-Wall Corrugated.....	7
3.7 Double-Wall Corrugated.....	7
4.0 GENERAL SPECIFICATIONS	8
4.1 Shipping Cartons and Inner Cartons.....	8
4.2 Care and Handling Markings	9
4.3 Protective Packaging Materials	10
4.4 Packing a Carton	11
4.5 Palletization	12
4.6 Loading	12
5.0 ADDITIONAL REQUIREMENTS	13
5.1 Oversized Items	13
5.2 Mirrors and Framed Arts	14
5.3 Lamps (Assembly Required)	14
5.4 Ceramics, Glassware and Crystal.....	14
5.5 Liquids and Oils.....	14
5.6 Natural Fiber Items.....	14

1.0 PURPOSE

The guidelines in this document describe the minimum packaging protection for fragile merchandise acceptable by Ross Stores, Inc., which includes **Ross Dress for Less** and **dd's DISCOUNTS**. The objective is to ensure the vendor's product arrives to the distribution centers and stores undamaged. For certain conditions and items, additional protection will be required beyond the minimum specifications called out in this document.

Any questions regarding this document, please contact the Distribution Centers Customer Service at: DC.CustomerService@ros.com or (803) 396-2211

Any reference to other Ross documents can be found on the [Ross Partners Portal](#).

2.0 CARTON PERFORMANCE TESTING

2.1 General Information

- Vendors must perform the Drop Test.
- Proof of carton testing must be provided to Ross upon Merchant request.

2.2 Conditioning

- The packaged products must be stored for 24 hours in the testing environment before testing. The tests should be conducted as soon as possible after the 24 hour conditioning period has been met.

2.3 Drop Test

- Perform 10 variations of drop tests at the height indicated in Table 1 below, based on carton weight.

Table 1

<i>Shipping Weight, lbs (kg)</i>	<i>Drop Height, inches (cm)</i>
0 - 61 (0 - 28)	18 (45.7)
61 - 100 (28 - 45)	12 (30.5)
100 - 150 (45 - 68)	8 (20)

1. Hold carton level to the ground, over a flat surface, oriented upright (arrows pointing up)
2. Drop carton in free-fall dead drop from the height specified in Table 1
3. Repeat free fall drops in Drop Sequence in Table 2, continuing with Sequence 2

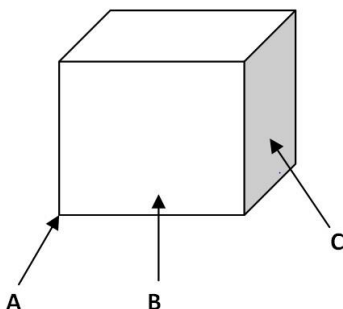

Table 2

<i>Sequence</i>	<i>Orientation</i>	<i>Specific face or edge</i>
1	Base	Bottom Face
2	Corner	Corner A
3	Edge	Shortest edge radiating from Corner A
4	Edge	Next shortest edge radiating from Corner A
5	Edge	Longest edge radiating from Corner A
6	Edge	Remaining bottom edge
7	Face	Face B
8	Face	Opposite side to Face B
9	Face	Face C
10	Face	Opposite side to Face C

2.4 Documentation

- Testing documentation must be presented to Ross merchants upon request

Date:	
Vendor:	
Styles:	

PACKAGE INFORMATION:

1. Container Dimensions:
2. Gross weight of packaged product:
3. Corrugated strength (i.e., 250 psi; 51 ECT):
4. Provide description of all packaging including Styrofoam, bubble wrap, etc.:

TESTING PERFORMED:

1. Was the test carton conditioned for 24 hours YES NO
2. Drop Test
 - a. Procedure A B
 - b. Free-Fall drop height:
 - c. # of Sequences:
3. Describe results of test below:

Provide photos of the test carton before and after testing.

3.0 PACKAGING TERMS

Definition of packaging terms

3.1 Item

A single piece of merchandise which can be sold open stock or in a ready-to-sell package

- *Note: A ready-to-sell package does not serve as a shipping or inner carton. Its purpose is sales merchandising to display an item on the sales floor), not product protection. Typically made of single-ply paper and many times has either a plastic window or unobstructed access to item. It serves no protective function.*

3.2 Shipping Carton

A shipping carton is the exterior corrugated carton that may contain a single item, multiple items or a set of inner cartons. It serves as the container that vendors affix the shipping label to and Distribution Centers will unload from trailers, place on conveyors, and possibly load onto trailers destined for stores.

3.3 Inner Carton

An inner carton is a corrugated carton that may contain one or multiple items and packed within a shipping carton

- Assortment and quantity configuration per shipping and/or inner carton must be prearranged with Buyer
- Items in store-ready cartons should be pre-ticketed. Any questions regarding pre-ticketing should be directed to preticket@ros.com.
- *Example of a shipping carton containing inner cartons:*



3.4 Carton Dimensions

When describing the length, width, and height of the cartons,

- **LENGTH** is the distance of the flap at the opening
- **WIDTH** is the distance perpendicular to the flap opening
- **HEIGHT** or **DEPTH** is the distance between openings of a carton

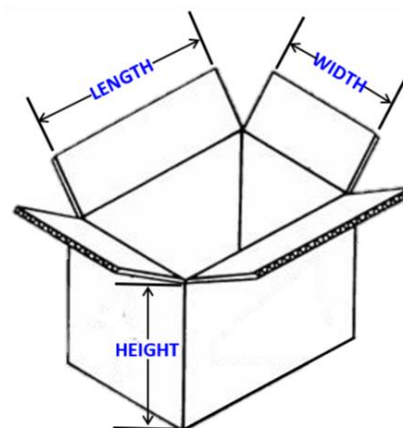

3.5 Flute

The ridges/waves in the corrugated medium

- The grade of the flute will determine the carton's burst and compression strength
- The direction of flute usually runs parallel to the carton's height which provides better stacking strength

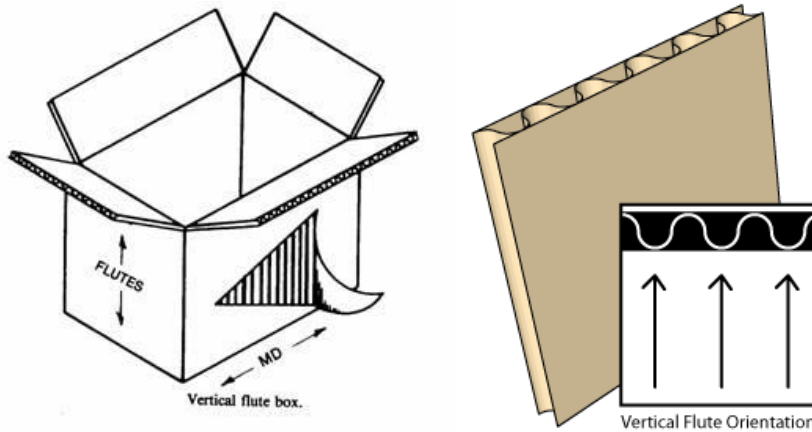

3.6 Single-Wall Corrugated

A corrugated medium made of 1 flute and 2 flat linerboards

Minimum Standard:

- Flute must be C-grade
- The medium must have a minimum Burst Strength Test of 200# and Edge Crush Test of 32 ECT



3.7 Double-Wall Corrugated

A corrugated medium made of 2 flutes and 3 flat linerboards

Minimum Standard:

- Flutes must be BC-grade
- The medium must have a minimum Burst Strength Test of 275# and Edge Crush Test of 48 ECT



4.0 GENERAL SPECIFICATIONS

This section provides general specifications on carton type, markings, packaging materials, packing a carton, palletization and loading. For additional requirements for specific product types, see [Section 5](#).

4.1 Shipping Cartons and Inner Cartons

4.1.1 Must use a regular slotted carton (RSC)

This applies to both shipping cartons and inner cartons. With RSC, all flaps are the same length, with the two major flaps being one-half of the carton's width so that they meet in the center of the carton when closed.



4.1.2 Reuse or repurpose used cartons is not acceptable

- This applies to both shipping cartons and inner cartons
- Cartons made from recycled cardboard are acceptable

4.1.3 Corrugated specifications based on item size and packing configuration

The table below states the minimum acceptable corrugated strength and quality for shipping cartons and inner cartons based upon the size of the items and inner carton configuration. Certain product type may require corrugated cartons of higher standards.

PRODUCT SIZE & PACK CONFIGURATION		CORRUGATED SPECIFICATIONS*	
ITEM DIMENSIONS	DOES SHIPPING CARTON HAVE INNER CARTONS?	SHIPPING CARTON	INNER CARTON
Height exceeds 12 inches	Yes	Single-Wall Corrugated	Double-Wall Corrugated
Height exceeds 12 inches	No	Double-Wall Corrugated	N/A
Width exceeds 16 inches	Yes	Single-Wall Corrugated	Double-Wall Corrugated
Width exceeds 16 inches	No	Double-Wall Corrugated	N/A
Length exceeds 22 inches	Yes	Single-Wall Corrugated	Double-Wall Corrugated
Length exceeds 22 inches	No	Double-Wall Corrugated	N/A
6" < Height < 12" 8" < Width < 16" 11" < Length < 22"	Yes	Single-Wall Corrugated	Double-Wall Corrugated
6" < Height < 12" 8" < Width < 16" 11" < Length < 22"	No	Double-Wall Corrugated	N/A
Height < 6", Width < 8", Length < 11"	Yes	Single-Wall Corrugated	Double-Wall Corrugated
Height < 6", Width < 8", Length < 11"	No	Double-Wall Corrugated	N/A

* Minimum standard on flute grade, burst strength and ECT for single and double-wall corrugated see [Section 3.6](#) and [3.7](#)

4.2 Care and Handling Markings

Care and handling markings are required on cartons with fragile content to provide instructions to handlers

4.2.1 All care and handling markings are required on both shipping cartons and inner cartons

4.2.2 Markings must be clearly visible on all 4 sides of the carton

4.2.3 Required markings:

- The word and icon “FRAGILE”
- “Handle with Care” icon
- “This End Up” icon for handling and stacking orientation. Arrows must be aligned with the carton’s height dimension which should match the correct flute orientation. See [Section 3.5](#) for definition of flute.

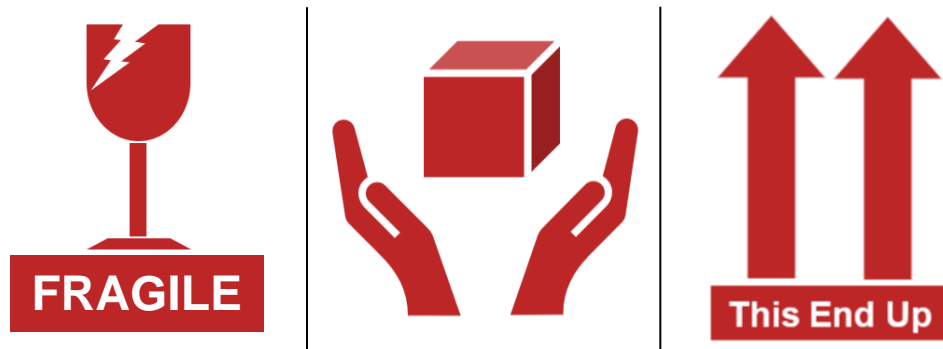

4.2.4 The following are other markings that may be required based on the item being shipped but not limited to:

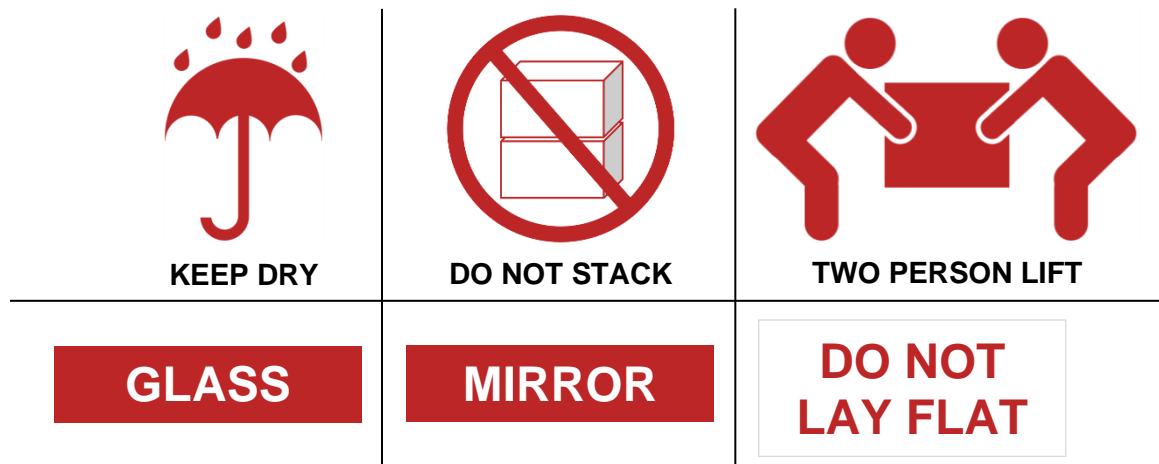

4.2.5 For all other standard carton labeling requirements, refer to the [“Vendor Shipping Guidelines”](#)

4.3 Protective Packaging Materials

Packaging material choice and the amount needed to protect the item are defined and agreed by the vendor and Buyer

4.3.1 Final packaging material configuration must protect item by

- Cushioning item from impact, shock, vibration
- Bracing item and filling void to prevent shifting during transit and distribution
- Separating item away from the carton walls and other items in the same carton

4.3.2 Acceptable protective packaging materials

AIR-FILLED

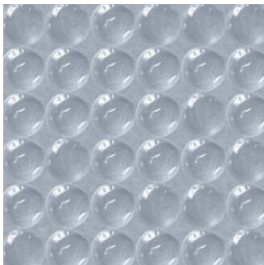

BUBBLE WRAP

Size: 3/16", 5/16"

- Bubble must face inward, towards product



AIR PILLOWS

CORRUGATED/FIBER MATERIAL



PARTITIONS/LINERS

- Partition height must be at least 3/4" higher than product
- Partition must be at least single-wall corrugated with minimum of 32 ECT
- Add corrugated pads to the top and bottom of the partition



CORNER PROTECTORS/POSTS

- The posts height must be the same length as carton depth
- Add a corrugated pad to rest on top of the posts

FOAM



COHESIVE POLYETHYLENE

Thickness: 1/16"



STYROFOAM

At least 3/4" thick



DIE-CUT INSERT



MOLDED PULP

Clamshell, Trays



MOLDED CLAMSHELL

- Clamshell must be properly sealed with no openings



CORNER PROTECTORS

4.4 Packing a Carton

General guidelines for packing a shipping carton and inner carton

4.4.1 Use the appropriate and correct size carton for the item's size and weight being packed

4.4.2 All items or inner cartons must be packed and shipped within a shipping carton

- Exception must be approved by Buyer

4.4.3 Using the appropriate and acceptable packaging material, listed in [Section 4.3.2](#), to protect carton's content

- Single item with multiple loose pieces must be secured together and need protection between each piece
- The irregular shaped on an item should be fully covered and protected
- Multiple units packed together in a single carton need protection from each other
- When wrapping item with cushioning material, each item must be wrapped separately and secured to item (packaging material must not come loose in transit or damage item when removed)

4.4.4 Items must be secured inside the carton and require clearance from all sides of the carton walls

- Should add appropriate packing material to prevent movement of items within carton. Any air-filled or paper-based void filler is acceptable.
- Items surrounded by packing material should provide at least a ¼" clearance between items and the carton walls (include the top, bottom)

4.4.5 Do not over-fill or under-fill the carton

4.4.6 All cartons should have rigid flaps that meet in the middle when the carton is closed and sealed

- Use of plastic strap to seal cartons is **not** acceptable

4.5 Palletization

Palletize shipment when possible and choose a pallet size that can be handled using a standard pallet jack and fork lift

4.5.1 Pallets should be sturdy and in good condition to support load

- Pallets on import shipments must be properly treated to prevent any infestation

4.5.2 Cartons should be stacked according to markings (i.e. adhere to “This End Up” marking)

4.5.3 Recommended pallet height for shipping is 6 feet

- For heavier products, height should **not** exceed 5 feet

4.5.4 Load on pallet must be properly secured with

- **Plastic Wrap Film**
 - Wrap around the entire load starting from the pallet’s top deck board to the top of load
 - Bottom should have at least 3-4 revolutions to ensure the stability
- **Edge Protectors/V-Boards** (*optional but recommended*)
 - Should use on all corners
 - Edge protector’s height must be the same as the load’s height
- **Corrugated Slip Sheet** (*optional but recommended*)
 - Insert a sheet between the pallet and the first layer
 - Insert a sheet in every other layer to ensure even weight distribution



4.5.5 Double stacking of pallets is only allowed when the bottom pallet is framed in wood or has a solid top to support the weight of the top pallet

- For certain product type which should be not be double stacked, add a label “Do Not Double Stack” to the pallets

4.6 Loading

4.6.1 On floor loaded, cartons should be loaded and stacked according to markings (i.e. adhere to “This End Up” marking)

- Exception is made on the top couple of rows for container cubing purposes

4.6.2 Shipper is responsible for bracing and securing the load or pallets in trailer to minimize shifting while in transit

5.0 ADDITIONAL REQUIREMENTS

This section provides additional requirements that are specific to a class of merchandise. Unless stated otherwise, [Section 4](#)'s General Specifications must be adhered in addition to other requirements outlined in this section.

5.1 Oversized Items

Oversized requirements hold for all merchandise categories except furniture. For furniture, refer to the "[Packaging Guidelines for Furniture](#)."

5.1.1 An oversized item after packaged meets at least one of the following conditions:

- One dimension of the item exceeds 22 inches
- Two dimensions of the item exceeds 16 inches
- Three Dimensions exceed 12 inches

5.1.2 Oversized items should be protected and placed into single-unit shipping carton. Follow [Section 4](#) for corrugated specifications and acceptable packaging materials.

5.1.3 Items weighing over 50 lbs. must be palletized

- Choose a pallet size that best fits the product. Half-pallet, quarter-pallets and custom pallets are acceptable for use with the stipulation that the pallet can be handled using a standard pallet jack and fork lift.
- Items must be securely wrapped and strapped to pallet



5.1.4 Large ceramic pottery store-ready pallets (packed in shipping carton is optional)

- Assortment and quantity configuration per pallet must be prearranged with Buyer
- For pallet size requirement, see above [Section 5.1.3](#)
- All pallets are **required** to be framed or crated
- Each pottery not in shipping carton must be wrapped with packaging material to prevent product-to-product and product-to-framed/pallet damage
- Pottery must be secured within the framed pallet



5.2 Mirrors and Framed Arts

Refer to the "[Packaging Guidelines for Mirrors and Framed Arts](#)"

5.3 Lamps (Assembly Required)

Refer to the "[Packaging Guidelines for Assembly Required Lamps](#)"

5.4 Ceramics, Glassware and Crystal

This category includes all ceramic, terracotta, resin, glass and crystal products

5.4.1 The shipping carton's total gross weight should not exceed 35 lbs.

5.5 Liquids and Oils

This category includes gourmet food, beverages, cosmetics, cleaning and auto solutions

5.5.1 Item must stand upright in carton

- "This End Up" marking on cartons must point the direction of the top of the merchandise

5.5.2 Partitions are the preferred method of separating liquids & oils

- Custom Styrofoam or corrugated design also acceptable

5.5.3 The shipping carton's total gross weight should not exceed 35 lbs.

5.6 Natural Fiber Items

This category includes products made of rattan, bamboo, seagrass, raffia or wood

5.6.1 All items must be pre-treated or fumigated to prevent infestation

5.6.2 Silica gel packets are required to keep the merchandise dry during shipping